



Power Clutches™

Answer for your high-speed, high-cyclic, heavy-duty industrial applications



Jeyson's PCB Series Pneumatic Clutch /Brake Combination

Jeysons Industries is in the business of manufacturing highly reliable and technically superior industrial clutches & brakes; providing strong engineering and technical support to clients interested in increasing their competitiveness and productivity in the ever-changing global market.

Our vision

To continually provide the best products & world class support to our customers by applying the highest standards of business processes which add value to our customers, suppliers and employees.

Our mission

To become India's leading **Manufacturer of Industrial Clutches & Brakes** by providing world-class quality and cost effective products to the world market. We will achieve this by offering an unparalleled level of service and commitment, which not only meets but exceeds our customer's expectations and requirements.

Through partnerships we will develop **Our people, Processes and Technology** to excel in business performance.

Our philosophy

At Jeysons, our philosophy is KISS (Keep It Simple Systems); we design and manufacture technically superior and competitively priced products. Our products are easy to use, have minimal downtime and lower operating & maintenance costs, while customers benefit from the highest level of customer satisfaction from us.

About us

Jeysons Industries launched its manufacturing operations in the year 2003. Suitably armed with an independent 4500 sq. ft. factory building, we work with a team of highly skilled professionals with 30 years experience in the field of manufacturing precision engineering products and components for some of the most critical industries of the world. Our quality control department too is at par with international standards where all instruments, gauges, jig & fixtures and machines are periodically calibrated. Testing, Identification and Traceability from Raw Material to Finished Products are standard norms followed by us. Even bought out components are identified and tracked in our well equipped systems.

Our products are field proven; 90% of our sales are from repeat customers and our products are running in 24x7 environments without breakdown or need for maintenance for years. **Our standard policy for all products is one year replacement warranty and 60 days no questions ask money back guarantee.**

PCB Series Pneumatic Clutch & Brake Combination

Jeyson's PCB Series Pneumatic Clutch/Brake Combination consists of air-actuated clutch and spring applied brake. Its compact and simple design combined with its high thermal capacity and low air consumption makes it ideal for today's high-speed, high-cyclic, heavy-duty industrial applications.

Three different types of disc attachments allow five possible standard mounting arrangements. We can also provide customer specific attachments.

The operation of our product is very simple. When the cylinder is pressured by compressed air, the piston clamps the clutch disc to the hub, which transmits the driving member torque to the driven shaft. When the cylinder exhausts, the spring's move back the piston and instant brake is applied, stopping the driven shaft. Overlapping cannot occur between clutching and braking operation. Efficient cooling permits a stable co-efficient of friction resulting in reproducible torque control. Minimal torque loss combined with generous long-life asbestos free friction lining results in lower operating and maintenance costs.

PCB Units are available in 12 standard sizes with clutch torque from 25Kg (250Nm) to 5000Kg (50000 Nm) and brake torque range from 15Kg (150Nm) to 3000Kg (30000 Nm)

Applications:

- Automatic Punching Machines
- Press Brakes
- Printing Machines
- Shears
- Stamping and Forming Presses
- Woodworking Machines



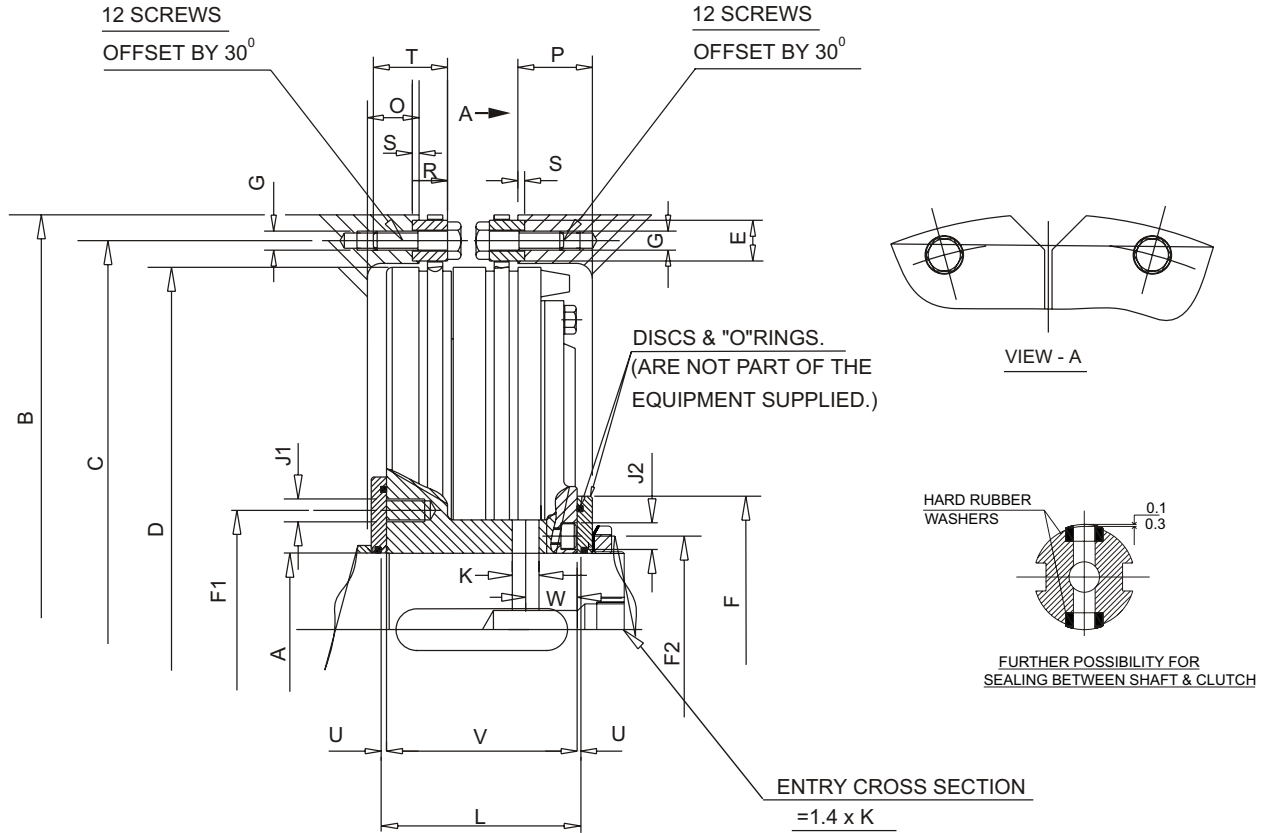

CLUTCH
BRAKE

MODEL	TYPE	PCB-1											
		SIZE	1002	1003	1004	1005	1006	1007	1008	1009	1010	1011	1012
TORQUE	CLUTCH	25	50	100	200	400	500	600	800	1200	1600	2500	5000
	BRAKE	15	30	60	120	250	300	360	500	720	1000	1500	3000
PILOT BORE	A(H7) Min.	15	25	35	45	45	55	60	70	90	100	115	150
	A(H7) Max.	35	45	65	80	95	105	110	125	145	160	180	240
Max. Keyway		10 x 3.3	14 x 3.8	18 x 4.4	22 x 5.4	25 x 5.4	28 x 6.4	28 x 6.4	32 x 7.4	36 x 8.4	40 x 9.4	45 x 10.4	56 x 12.4
D I A M E T E R S	B	220	275	347	435	535	570	620	680	775	865	1000	1145
	C(JS10)	205	255	325	408	500	536	584	640	725	810	945	1080
	D	188	236	304	380	465	497	543	593	675	755	885	1015
	E(h8)	10	12	15	18	25	25	25	30	35	40	42	50
	F	70	85	125	145	170	175	190	210	240	265	305	400
	F1	60	75	105	125	155	170	180	195	230	250	255	520
	F2	47	57	81	98	115	130	135	150	175	190	255	285
	G	M5	M6	M8	M10	M14	M14	M14	M16	M20	M24	M24	M27
	J1	M8 x 8	M8 x 8	M12 x 12	M12 x 20	M16 x 20	M20 x 25	M20 x 25	M24 x 25	M24 x 35	M24 x 35	M24 x 35	M24 x 35
	J2	9	9	14	14	17	17	19.5	19.5	23.5	25.5	28	42
	K	6	9	12	14	14	17	17	17	23	23	28	32
L E N G T H	L	64	74	90	110	135	150	155	170	195	213	265	305
	O	12	15	18	22.5	26.5	29.5	29.5	31	35.5	38	45	51
	P	21	24	30.5	36.5	42.5	48	49.5	56	64.5	69.5	95	125
	R	11	13	16	19	22	26	26	27	32	37	40	50
	S	2	2	3	3	3	3	3	5	5	5	5	10
	T	20	25	30	35	45	50	50	55	70	80	80	100
	U	3	4	4	5	5	5	5	5	5	5	5	5
	V	58	66	82	100	125	140	145	160	185	203	255	295
	W	17	18.5	23	27	32	36	36.5	42	48	53	67	76

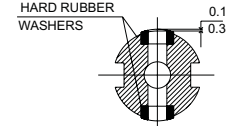
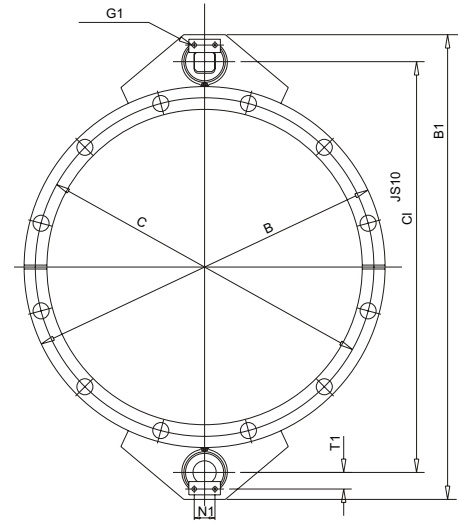
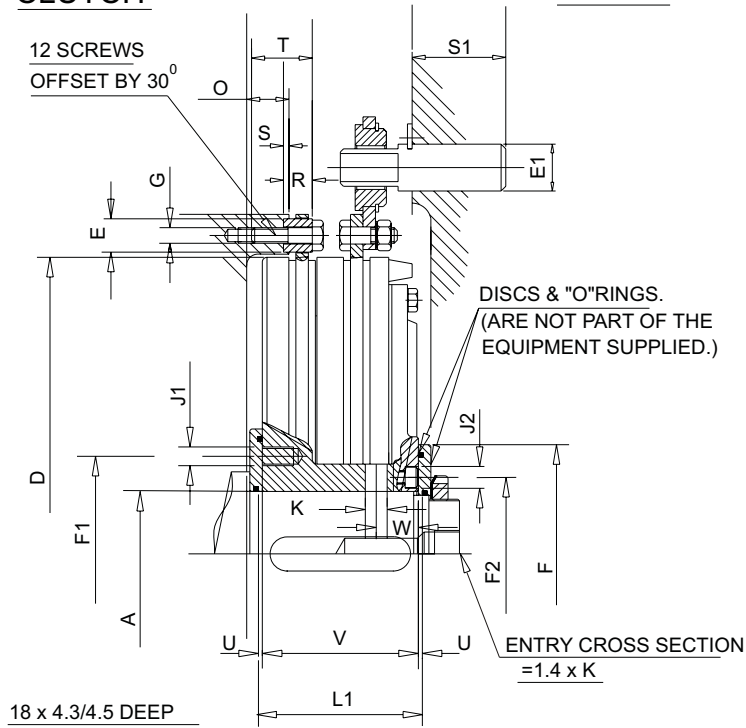

CLUTCH

BRAKE



FURTHER POSSIBILITY FOR
SEALING BETWEEN SHAFT & CLUTCH

MODEL	TYPE	PCB-2											
	SIZE	1002	1003	1004	1005	1006	1007	1008	1009	1010	1011	1012	1013
TORQUE KGM	CLUTCH	25	50	100	200	400	500	600	800	1200	1600	2500	5000
	BRAKE	15	30	60	120	250	300	360	500	720	1000	1500	3000
PILOT BORE	A(H7) Min.	15	25	35	45	45	55	60	70	90	100	115	150
	A(H7) Max.	35	45	65	80	95	105	110	125	145	160	180	240
Max. Keyway		10x3.3	14x3.8	18x4.4	22x5.4	25x5.4	28x6.4	28x6.4	32x7.4	36x8.4	40x9.4	45x10.4	56 x 12.4
D I A M E T E R S	B	220	275	347	435	535	570	620	680	775	865	1000	1145
	B1	282	360	435	560	695	730	780	870	1000	1090	1285	1460
	C(JS10)	205	255	325	408	500	536	584	640	725	810	945	1080
	C1(JS10)	250	315	390	495	610	645	695	770	880	970	1140	1300
	D	188	236	304	380	465	497	543	593	675	755	885	1015
	E(h8)	10	12	15	18	25	25	25	30	35	40	42	50
	E1(k6)	14	22	22	30	40	40	40	45	55	55	65	75
	F	70	85	125	145	170	175	190	210	240	265	305	400
	F1	60	75	105	125	155	170	180	195	230	250	255	520
	F2	47	57	81	98	115	130	135	150	175	190	255	285
	G	M5	M6	M8	M10	M14	M14	M14	M16	M20	M24	M24	M27
	G1	4.5	5.5	5.5	5.5	6.5	6.5	6.5	6.5	8.5	8.5	8.5	10.5
	J1	M8x8	M8x8	M12x12	M12x20	M16x20	M20x25	M20x25	M24x25	M24x35	M24x35	M24x35	M24x35
	J2	9	9	14	14	17	17	19.5	19.5	23.5	25.5	28	42
K	6	9	12	14	14	17	17	17	23	23	28	32	
L E N G T H	L1	64	76	90	110	135	150	155	170	195	213	265	305
	N1	20	25	25	25	35	35	35	35	45	45	45	60
	O	12	15	18	22.5	26.5	29.5	29.5	31	35.5	38	45	51
	R	11	13	16	19	22	26	26	27	32	37	40	50
	S	2	2	3	3	3	3	3	5	5	5	5	10
	S1	28	45	45	60	80	80	80	90	110	110	130	150
	T1	11	16	16	20	27	27	27	29.5	38.5	38.5	43.5	52.5
	U	3	4	4	5	5	5	5	5	5	5	5	5
	V	58	66	82	100	125	140	145	160	185	203	255	295
	W	17	18.5	23	27	32	36	36.5	42	48	53	67	76



CLUTCH

BRAKE

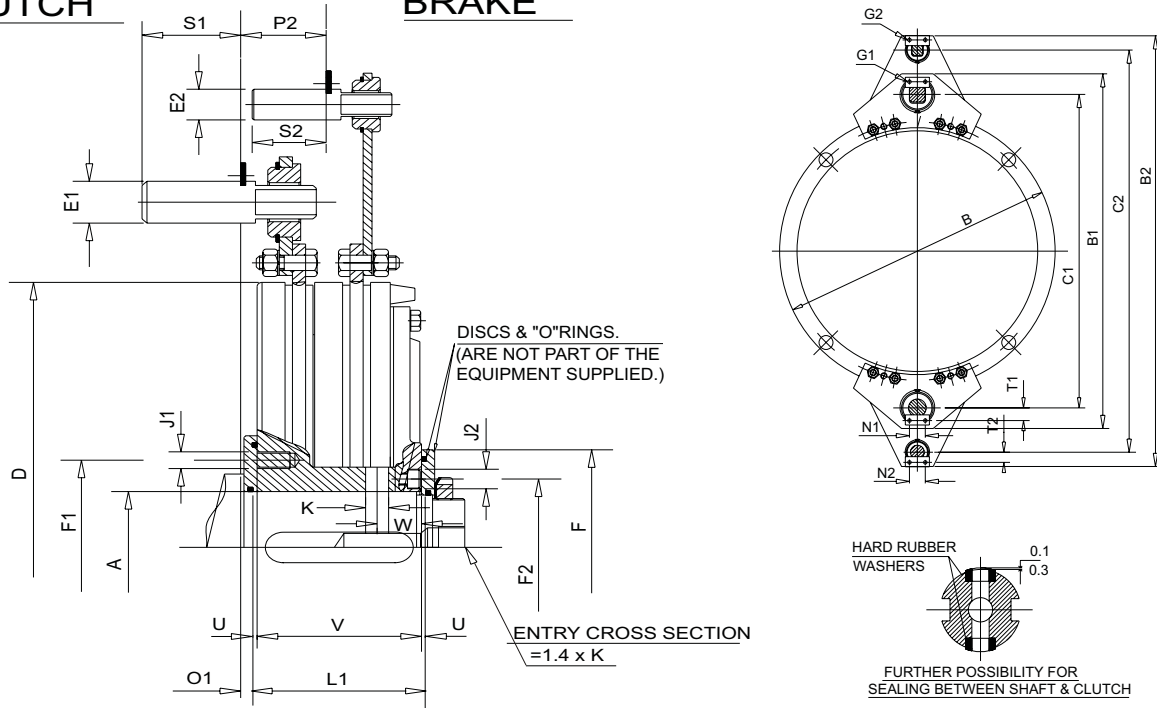

MODEL	TYPE	PCB-3											
	SIZE	1002	1003	1004	1005	1006	1007	1008	1009	1010	1011	1012	1013
TORQUE KGM	CLUTCH	25	50	100	200	400	500	600	800	1200	1600	2500	5000
	BRAKE	15	30	60	120	250	300	360	500	720	1000	1500	3000
PILOT BORE	A(H7) Min.	15	25	35	45	45	55	60	70	90	100	115	150
	A(H7) Max.	35	45	65	80	95	105	110	125	145	160	180	240
Max. Keyway		10x3.3	14x3.8	18x4.4	22x5.4	25x5.4	28x6.4	28x6.4	32x7.4	36x8.4	40x9.4	45x10.4	56 x 12.4
D I A M E T E R S	B	220	275	347	435	535	570	620	680	775	865	1000	1145
	B1	282	360	435	560	695	730	780	870	1000	1090	1285	1460
	B2	357	442	522	680	855	895	950	1075	1235	1335	1570	1790
	C1(JS10)	250	315	390	495	610	645	695	770	880	970	1140	1300
	C2(JS10)	325	410	490	635	790	830	885	990	1135	1235	1450	1645
	D	188	236	304	380	465	497	543	593	675	755	885	1015
	E1(k6)	14	22	22	30	40	40	40	45	55	55	65	75
	E2(k6)	14	14	14	22	30	30	30	40	45	45	55	65
	F	70	85	125	145	170	175	190	210	240	265	305	400
	F1	60	75	105	125	155	170	180	195	230	250	255	520
	F2	47	57	81	98	115	130	135	150	175	190	255	285
	G1	4.5	5.5	5.5	5.5	6.5	6.5	6.5	6.5	8.5	8.5	8.5	10.5
	G2	4.5	4.5	4.5	5.5	5.5	5.5	5.5	6.5	6.5	6.5	8.5	8.5
	J1	M8x8	M8x8	M12x12	M12x20	M16x20	M20x25	M20x25	M24x25	M24x35	M24x35	M24x35	M24x35
	J2	9	9	14	14	17	17	19.5	19.5	23.5	25.5	28	42
	K	6	9	12	14	14	17	17	17	23	23	28	32
L E N G T H	L1	64	74	90	110	135	150	155	170	195	213	265	305
	N1	20	25	25	25	35	35	35	35	45	45	45	60
	N2	20	20	20	25	25	25	25	35	35	35	45	45
	O1	5.5	8.5	8.5	10	12.5	12.5	12.5	13.5	15	15	16.5	22.5
	P2	29.5	39	49	52	68.5	80	83.5	84	101	110.5	120.5	134.5
	S1	28	45	45	60	80	80	80	90	110	110	150	150
	S2	28	28	28	45	60	60	60	80	90	90	130	130
	T1	11	16	16	20	27	27	27	29.5	38.5	38.5	43.5	52.5
	T2	11	11	11	16	20	20	20	27	29.5	29.5	38.5	43.5
	U	3	4	4	5	5	5	5	5	5	5	5	5
	V	58	66	82	100	125	140	145	160	185	203	255	295
W	17	18.5	23	27	32	36	36.5	42	48	53	67	76	



CLUTCH

BRAKE

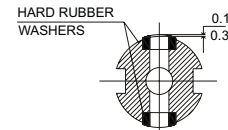
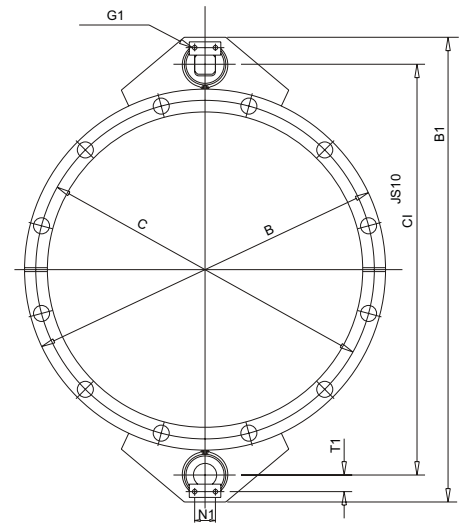
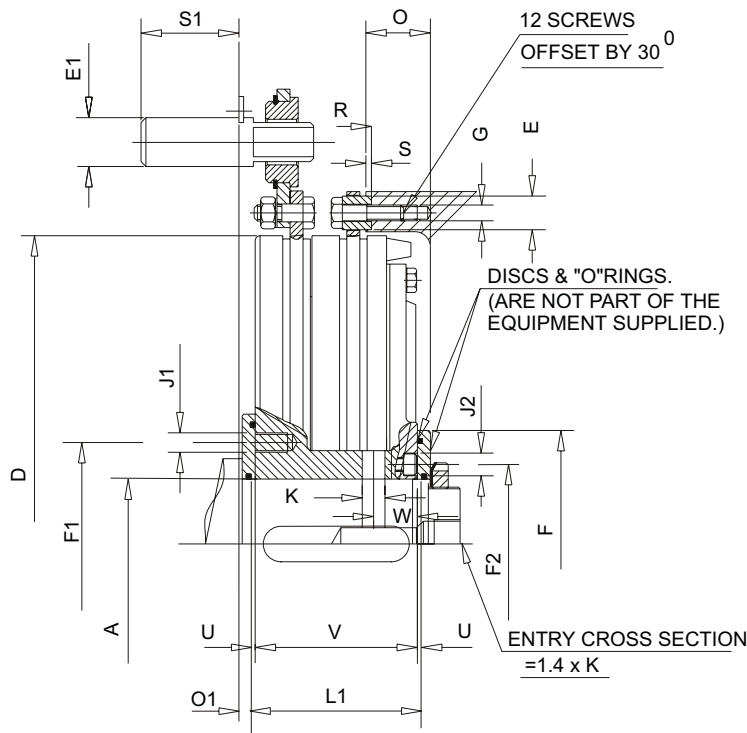

FURTHER POSSIBILITY FOR
SEALING BETWEEN SHAFT & CLUTCH

MODEL	TYPE	PCB-4											
	SIZE	1002	1003	1004	1005	1006	1007	1008	1009	1010	1011	1012	1013
TORQUE KGM	CLUTCH	25	50	100	200	400	500	600	800	1200	1600	2500	5000
	BRAKE	15	30	60	120	250	300	360	500	720	1000	1500	3000
PILOT BORE	A(H7) Min.	15	25	35	45	45	55	60	70	90	100	115	150
	A(H7) Max.	35	45	65	80	95	105	110	125	145	160	180	240
Max. Keyway		10x3.3	14x3.8	18x4.4	22x5.4	25x5.4	28x6.4	28x6.4	32x7.4	36x8.4	40x9.4	45x10.4	56x12.4
D I A M E T E R S	B	220	275	347	435	535	570	620	680	775	865	1000	1145
	B1	282	360	435	560	695	730	780	870	1000	1090	1285	1460
	C (JS10)	205	255	325	408	500	536	584	640	725	810	945	1080
	C1(JS10)	250	315	390	495	610	645	695	770	880	970	1140	1300
	D	188	236	304	380	465	497	543	593	675	755	885	1015
	E (h8)	10	12	15	18	25	25	25	30	35	40	42	50
	E1(k6)	14	22	22	30	40	40	40	45	55	55	65	75
	F	70	85	125	145	170	175	190	210	240	265	305	400
	F1	60	75	105	125	155	170	180	195	230	250	255	520
	F2	47	57	81	98	115	130	135	150	175	190	255	285
	G	M5	M6	M8	M10	M14	M14	M14	M16	M20	M24	M24	M27
	G1	4.5	5.5	5.5	5.5	6.5	6.5	6.5	6.5	8.5	8.5	8.5	10.5
	J1	M8x8	M8x8	M12x12	M12x20	M16x20	M20x25	M20x25	M24x25	M24x35	M24x35	M24x35	M24x35
	J2	9	9	14	14	17	17	19.5	19.5	23.5	25.5	28	42
K	6	9	12	14	14	17	17	17	23	23	28	32	
L E N G T H	L1	64	74	90	110	135	150	155	170	195	213	265	305
	N1	20	25	25	25	35	35	35	35	45	45	45	60
	O	12	15	18	22.5	26.5	29.5	29.5	31	35.5	38	45	51
	O1	5.5	8.5	8.5	10	12.5	12.5	12.5	13.5	15	15	16.5	22.5
	R	11	13	16	19	22	26	26	27	32	37	40	50
	S	2	2	3	3	3	3	3	5	5	5	5	10
	S1	28	45	45	60	80	80	80	90	110	110	130	150
	T1	11	16	16	20	27	27	27	29.5	38.5	38.5	43.5	52.5
	U	3	4	4	5	5	5	5	5	5	5	5	5
	V	58	66	82	100	125	140	145	160	185	203	255	295
	W	17	18.5	23	27	32	36	36.5	42	48	53	67	76



CLUTCH

BRAKE

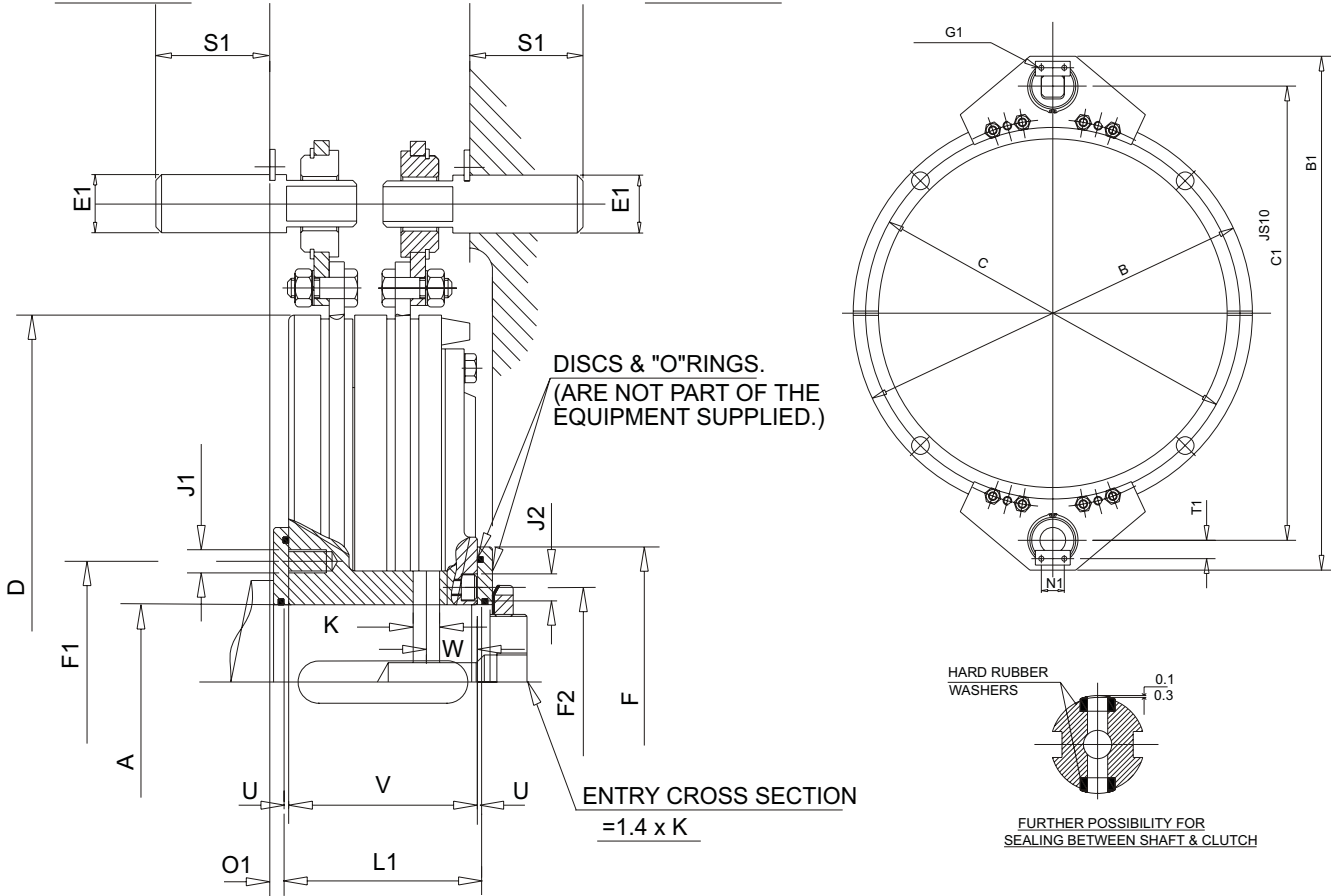

MODEL	TYPE	PCB-5												
	SIZE	1002	1003	1004	1005	1006	1007	1008	1009	1010	1011	1012	1013	
TORQUE KGM	CLUTCH	25	50	100	200	400	500	600	800	1200	1600	2500	5000	
	BRAKE	15	30	60	120	250	300	360	500	720	1000	1500	3000	
PILOT BORE	A(H7) Min.	15	25	35	45	45	55	60	70	90	100	115	150	
	A(H7) Max.	35	45	65	80	95	105	110	125	145	160	180	240	
Max. Keyway		10x3.3	14x3.8	18x4.4	22x5.4	25x5.4	28x6.4	28x6.4	32x7.4	36x8.4	40x9.4	45x10.4	56x12.4	
D I A M E T E R S	B	220	275	347	435	535	570	620	680	775	865	1000	1145	
	B1	282	360	435	560	695	730	780	870	1000	1090	1285	1460	
	C1(JS10)	250	315	390	495	610	645	695	770	880	970	1140	1300	
	D	188	236	304	380	465	497	543	593	675	755	885	1015	
	E1(k6)	14	22	22	30	40	40	40	45	55	55	65	75	
	F	70	85	125	145	170	175	190	210	240	265	305	400	
	F1	60	75	105	125	155	170	180	195	230	250	255	520	
	F2	47	57	81	98	115	130	135	150	175	190	255	285	
	G1	4.5	5.5	5.5	5.5	6.5	6.5	6.5	6.5	8.5	8.5	8.5	10.5	
	J1	M8x8	M8x8	M12x12	M12x20	M16x20	M20x25	M20x25	M24x25	M24x35	M24x35	M24x35	M24x35	
	J2	9	9	14	14	17	17	19.5	19.5	23.5	25.5	28	42	
	K	6	9	12	14	14	17	17	17	23	23	28	32	
L E N G T H	L1	64	74	90	110	135	150	155	170	195	213	265	305	
	N1	20	25	25	25	35	35	35	35	45	45	45	60	
	O1	5.5	8.5	8.5	10	12.5	12.5	12.5	13.5	15	15	16.5	22.5	
	S1	28	45	45	60	80	80	80	90	110	110	130	150	
	T1	11	16	16	20	27	27	27	29.5	38.5	38.5	43.5	52.5	
	U	3	4	4	5	5	5	5	5	5	5	5	5	
	V	58	66	82	100	125	140	145	160	185	203	255	295	
	W	17	18.5	23	27	32	36	36.5	42	48	53	67	76	

JEYSONS RANGE OF PRODUCTS



Friction Clutches

- Torque: 0.6-34,128Nm (5-302,000 in.-lb.)
- Bore: 10-165 mm (0.375-6.5 in.)
- Air engaged/spring-released models
- High heat dissipation
- High dynamic torque
- Long friction facing life
- Self-adjusting for friction facing wear
- Single or multi-plate clutch models
- Inch and metric models available
- Accurately adjustable torque
- Variable mounting options on either the motor or drive shaft with a pulley, sprocket or flexible coupling on the pilot.

Tooth Clutches

- Torque: 3-6779Nm (20-60,000 in.-lb.)
- Bore: 13-100 mm (0.625-3.938 in.)
- Air engaged/spring-released models
- Spring-engaged/air-released models
- Single or multi-position models
- Inch and metric sizes available
- Positive engagement; no slipping
- Fast response time
- Variable mounting options on either the motor or drive shaft with a pulley, sprocket or flexible coupling on the pilot.

Safety chucks

- Redundant safety mechanisms securely lock shaft in place.
- Foot or flange mounting
- Long maintenance-free life.
- Shaft extension with keyway
- Inch and metric models available
- Available in ready-to-assemble brake packages.

Friction brakes

- Torque: 2-33,900Nm (18-300,000 in.-lb.)
- Bore: 10-165 mm (0.375-6.500 in.)
- Air engaged/spring-released models
- High heat dissipation
- High friction work capacity
- Straight or tapered bore
- Inch and metric models available
- Self-adjusting for friction facing wear
- Split friction facings for fast and easy replacement
- Variable mounting options: horizontal and vertical mounting in a range of shaft sizes.

One-way Clutch / Freewheels / Backstops

- Torque: 60-33,900Nm (530-300,000 in.-lb.)
- Bore: 12mm-150mm (0.5-5.90 in.)
- Different flange mounting models available.
- Inch and metric models available
- Outstanding reliability combined with maintenance free operation.
- Highly reliable, durable and trouble free design, improves productivity and safety
- Maximum torque in minimum space
- Roller and Sprag types model available
- Operating temperature range from -20 to +80°C
- Easy to use

Timing Belt Pulley

- Available in steel, cast iron, aluminium or any custom grade material.
- Available in different sizes and pitch configuration
- Keyways and Taper Bush design
- Bore Size made to order.
- Flange and Non-flange models

Order example

Type	Size	Friction Facing	Casting	Bore	Keyway
PCB- _		- -			

1 - 5 ————
 6 - Custom ————

1002 - 1013 ————

A - Asbestos ————
 F - Asbestos Free ————

B - Bonding ————
 R - Riveting ————

S - S.G. Iron (Gr. 500/7) ————
 C - Cast Iron (Gr. 25) ————

According to size ————
 According to size ————

In accordance with Jeyson's established quality policy for continual product improvement, the specifications contained in this document are subject to change without notice. Technical data listed in this document are based on the latest information available at the time of printing and are also subject to change without notice. For current information, please visit www.jeysons.com.



**JEYSONS
INDUSTRIES**

4(D) Government Indl. Est., Charkop,
Kandivli (W), Mumbai - 400 067. INDIA
Phone: 91-22-28683066/67 Fax: 91-22-28674137
Email: sales@jeysons.com, Web: www.jeysons.com

Distributor

